

2640 Series Averaging Transverse Extensometer | 2640-010

The 2640 series averaging transverse extensometer is designed to measure average transverse gauge length and strain with a single output channel.

Features and Benefits

- Measurement of transverse strain
- Averaging of transverse measurements
- Includes gauge width extenders
- Integral overload protection allows testing to specimen failure
- Packed into a special presentation case

Principle of Operation

Average transverse strain can be measured over a range of widths from 10 mm to 25 mm (0.4 in to 1 in) and contraction up to 10 mm (0.4 in). It is suitable for use in 'R&N' testing on sheet metals with an appropriate axial extensometer of 50 mm (2 in) gauge length minimum.

The averaging transverse extensometer consists of two extensometers of ± 5 mm (± 0.2 in) travel, which are fixed together at a 25 mm (1 in) gauge length. At the end of each arm is a measuring contact and a cone for ease-of-fitting.

The range of measuring widths are achieved by using two gauge length extenders. The 2640 series extensometers are designed for uni-directional tensile testing only, and are not suitable for strain control.

Application Range

- Static use only
- Suitable in 'R' value (Anisotropy Ratio) testing on metals

Specimen Sizes

- Gauge width 10 mm to 25 mm (0.4 in to 1 in)
- Thickness 0.3 mm to 4 mm (0.12 in to 0.16 in)
- Contraction 10 mm maximum (0.4 in)



Specifications

Gauge Width Range ¹		10 mm to 20 mm (0.4 in to 0.78 in) 15 mm to 25 mm (0.59 in to 1 in)
Width Travel	mm	±5
	in	±0.2
Length (L)	mm	96
	in	3.8
Width (W)	mm	50
	in	2
Depth (D)	mm	34
	in	1.3

Note: Gauge width is dependent on specimen

Parameters Spec

Linearity	±0.2% of Full-Scale Deflection (FSD)
Repeatability	0.1% of FSD
Creep	±0.2% of FSD
Bridge Resistance (Nominal)	350 Ω
Excitation	5V DC to 5kHz
Temperature Range	-80 °C to + 100 °C (-112 °F to + 212 °F)
Overtravel	Mechanical limit stops
Frequency Range	Static use only recommended

Note: Each calibration is performed at ambient temperature

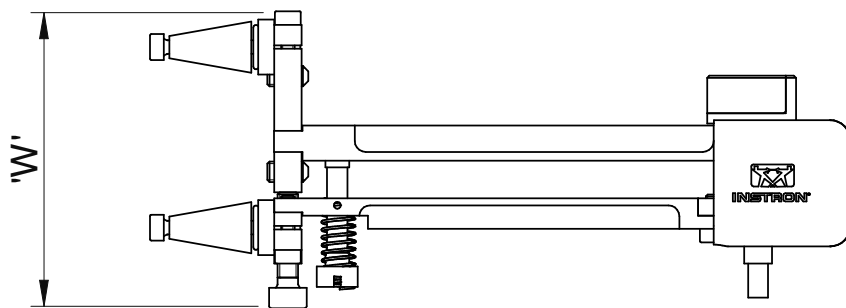
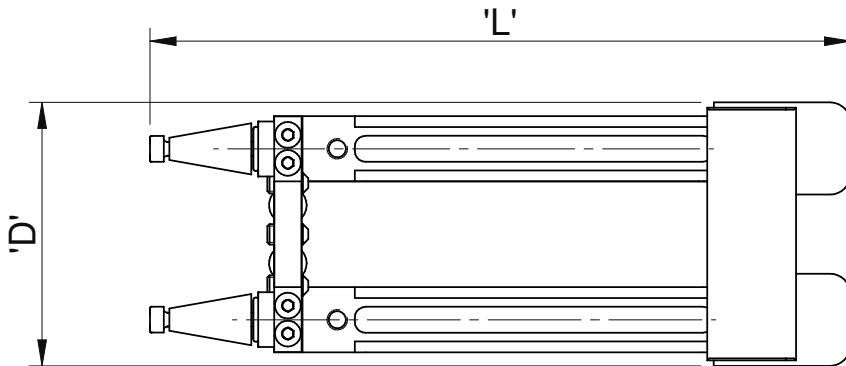

2640 series averaging transverse extensometer dimensions

www.instron.com/accessories



Worldwide Headquarters
825 University Ave, Norwood, MA 02062-2643, USA
Tel: +1 800 564 8378 or +1 781 575 5000

Instron Industrial Products
900 Liberty Street, Grove City, PA 16127, USA
Tel: +1 724 458 9610

European Headquarters
Coronation Road, High Wycombe, Bucks HP12 3SY, UK
Tel: +44 1494 464646